

# TYSONIC BATTERIES

## SPECIFICATION SHEET FOR TY-PRIZ-F6-700

### 1. APPLICATION

This specification applies to the Sealed Nickel-Metal hydride rechargeable cell or battery:  
 Model: TY-PRIZ-F6-700

### 2. RATINGS

● Nominal Voltage	<u>1.2</u> V
● Rated (minimum) capacity *1	<u>700</u> mAh
● Standard charge rate	<u>70</u> mA × 16h
● Rapid charge rate	<u>700</u> mA (stop when voltage reduce to 5-10mV) *2
Value of dT/dt (for reference only)	<u>1 to 2</u> °C/min
Trickle current	<u>14 to 35</u> mA (Need timer)
● Discharge cut-off voltage	(n × 1.0)V (n= 1--6) {(n-1) × 1.2}V (n=7--10) (n: cell number)
● Operating temperature range	(Humidity: +65% ± 20%)
Standard charge	0 to +45°C (32 to 113°F)
Rapid charge	0 to +40°C (32 to 104°F)
Discharge	-10 to +65°C (14 to 149°F)
● Storage temperature range	(Humidity : +65% ± 20%)
Within 1 year *3	-20 to +35°C (-4 to 95°F)
Within 6 months	-20 to +45°C (-4 to 113°F)
Within 1 month	-20 to +55°C (-4 to 131°F)
Within 1 week	-20 to +65°C (-4 to 149°F)

- \*1. Rated capacity figures are based on single cell performance.
- \*2. All rapid charge systems should be discussed with our engineer.
- \*3. We recommend cells or batteries are charged at least once every 6 months.

When operation falls outside these parameters please contact our engineer.

### 3. ASSEMBLY & DIMENSIONS

As per followed drawing:

Width	17.0 – 0.7mm
Height	46.5 – 1.0mm
Thickness	6.1 – 0.7mm

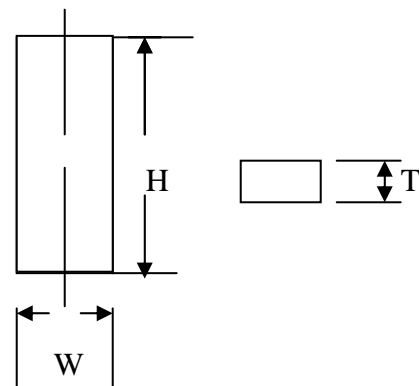

# TYSONIC BATTERIES

---

## 4.PERFORMANCE

### 4-1. TEST CONDITIONS

All tests are carried out on new cell or batteries. (Within one month after delivery)

Ambient conditions:

Temperature	+20°C ± 5°C
Humidity	+65% ± 20%

### 4-2. TEST APPLIANCES

#### 4-2-1. Voltage meter:

0.5 level or higher as required in IEC51/IEC485. Internal impedance exceeds 10K Ω /V.

#### 4-2-2. Current meter:

0.5 level or higher as required in IEC51/IEC485. Internal impedance should be less than 0.01 Ω /V(including wires).

#### 4-2-3. Micrometer caliper:

With precision of 0.02mm.

#### 4-2-4. Internal impedance meter:

Alternating current of 1000HZ, connector measuring equipment with sin wave of 4.

#### 4-2-5. Impedance loaded meter:

Value of impedance is with ±5% error allowed (including external wires).

### 4-3. TEST METHOD & PERFORMANCE

#### 4-3-1. Outer appearance:

Cells and batteries shall be free from any stains; scratches or deformations, which may reduce the commercial value of the product when visually inspected.

#### 4-3-2. Size:

The size shall comply with the specified value in the attached drawing when measured by micrometer caliper.

#### 4-3-3. Insulate impedance:

Checked by MM Ω meter, value of insulation between electrode and outer sleeve shall exceed 10 M Ω .

#### 4-3-4. Weight:

The cell weights approx 15 g measured by scale.

#### 4-3-5. Charge Voltage:

Following a period of discharge at 1CmA down to a terminal voltage of 1.0V, standard charge, the cell or battery shall be checked at 5 minutes before finish charging, The voltage shall be less than 1.6 V.

#### 4-3-6. Open circuit voltage: (O.C.V.)

Following a standard charge period, the open circuit voltage of the cell or battery shall be checked within 1 hour. The O.C.V. shall exceed 1.25 V per cell.

#### 4-3-7. Closed circuit voltage: (C.C.V.)

Following a standard charge period, the closed circuit voltage of the cell or battery shall be checked with a 0.86 Ω per cell load within 1 hour. The C.C.V. shall exceed 1.2 V per cell within 1 sec.

#### 4-3-8. Internal impedance:

# TYSONIC BATTERIES

---

Following a standard charge period, the internal impedance of the cell or battery shall be checked at 1000Hz within 1 hour. The internal impedance shall not be more than 40 m $\Omega$  per cell.

#### 4-3-9. Capacity:

Following a standard charge period, the cell shall be stored for a period of 1 hour. The capacity shall be equal or more than rated capacity when discharged at 0.2C mA down to a terminal voltage of 1.0V. The capacity returned might not initially attain the specified value following the first charge –discharge cycle. In this event, the test may be repeated a further two or three times to attain the specified value.

#### 4-3-10. High rate discharge:

Following a standard charge period, the cell or battery shall be stored for 1 hour. The discharge duration shall exceed 54 min(s) when discharged at 1C mA.

#### 4-3-11. Self discharge:

Following a period of discharge at 0.2C mA down to a terminal voltage of 1.0V, standard charge and then the cell or battery shall be stored on open circuit for 28 days. The subsequent capacity shall not be less than 60% of rated capacity when discharged at 0.2C mA.

#### 4-3-12. Over-charge:

Following a period of discharge at 0.2C mA down to a terminal voltage of 1.0V, standard charge and then charge for 48hrs at 0.1C mA. The capacity of the cell or battery shall not be less than the rated capacity when discharged at 0.2C mA. It shall not be externally deformed and no leakage of electrolyte in liquid form shall be observed.

#### 4-3-13. Over-discharge:

Following a period of discharge at 1C mA down to a terminal voltage of 1.0V, combine the cells with a 0.86  $\Omega$  per cell load. After stored for a period of 24 hours, standard charged and then discharge at 0.2C mA, the cell or battery shall not be externally deformed and no leakage of electrolyte in liquid form shall be observed, and the subsequent capacity shall not be less than 80% of rated capacity

#### 4-3-14. Life time (Based on clause 4.4.1, IEC285 1993):

The charge-discharge cycles shall exceed 500 times.

#### 4-3-15. Humidity:

No leakage of electrolyte in liquid form shall be observed during 14 days of storage (cell is in standard charged state) under the following storage conditions:

33°C  $\pm$  3°C (91.4°F  $\pm$  5.4°F)

Relative humidity of 80%  $\pm$  5%. (Salting is permitted).

#### 4-3-16. Vibration:

Store the cell or battery more than 24 hours after standard charge, following vibration tests over an amplitude of 4 mm (0.1575 inches) at a frequency of 16.7 Hz (1000 cycles per minute) and repeated through any axes during 60mins, the subsequent fluctuation of open circuit voltage and internal impedance shall be less than 0.02 V and 5 m $\Omega$  respectively, and the cell or battery shall not be externally deformed and no leakage of electrolyte in liquid form shall be observed.

#### 4-3-17. Free falling: (Drop)

Store the cell or battery more than 24 hours after standard charge, following a drop test from 450mm (17.717 inches) on to a hard-wood board in a vertical axis 2 times on each of 2 mutually perpendicular axes, the subsequent fluctuation of open circuit voltage and internal impedance shall be less than 0.02 V and 5 m $\Omega$  respectively, and the cell or

# TYSONIC BATTERIES

---

battery shall not be externally deformed and no leakage of electrolyte in liquid form shall be observed.

#### 4-3-18.Short:

Store the cell or battery for 1 hour after standard charge, it shall not explode during or at the end of a 1 hour short-circuit test. However, leakage of electrolyte, external deformation or outer sleeve cracking is permitted. (cross section of the wire should be more than  $0.75\text{mm}^2$ , length should be the shortest distance between 2 polarities)

#### 4-3-19. Incorrect polarity charging:

The cell or battery shall not explode during or at the end of a 5-hour period of incorrect polarity charging at 1C mA. However, leakage of electrolyte, external deformation or outer sleeve cracking is permitted.

#### 4-3-20. Incorrect polarity over-charging:

The cell or battery shall not explode during or at the end of a 5-hour period of incorrect polarity over-charging at 1C mA. However, leakage of electrolyte, external deformation or outer sleeve cracking is permitted.

#### 4-3-21. Low temperature discharge:

After standard charged, the cell or battery shall be stored for 24 hours at  $0^\circ\text{C} \pm 2^\circ\text{C}$ . The discharge duration shall exceed 3 hour(s) 30 min(s) when discharged at 0.2C mA at ambient temperature of  $0^\circ\text{C} \pm 2^\circ\text{C}$ .

## 5. OTHERS

5-1. The cell or battery shall be charged state at shipping.

#### 5-2. Cut-off voltage:

- We recommend a cut-off voltage of 1.0 to 1.1V per cell.
- If the cut-off voltage is above 1.1V per cell, the battery may be underutilized resulting in insufficient use of the available capacity.
- If the cell voltage drops below 1.0V per cell, the battery may become over discharged or reverse charged.

\*\*\*\*\* **END** \*\*\*\*\*

# TYSONIC BATTERIES

---

## Ni-MH Battery; Example on rapid charge system

### 1. Basic charge system

- |   |                      |
|---|----------------------|
| 1) Rapid charge current                                       | :0.5C to 1.0C mA     |
| 2) Charge current to voltage for rapid charge                 | :0.2C to 0.3C mA     |
| 3) Start voltage of rapid charge                              | :above 0.8V per cell |
| 4) Upper limit voltage ( to trickle charge)                   | :1.8V per cell       |
| 5) Value of minus delta V(- $\Delta$ V)                       | :5 to 10 mV per cell |
| 6) Temperature increase rate (dT/dt)                          | :1 to 2°C/min        |
| 7) Upper limit temperature (Tco)                              | :50°C                |
| 8) Initial non-detection timer of minus delta V(- $\Delta$ V) | :5 to 10 min         |
| 9) Trickle charge current                                     | :1/20C to 1/30C mA   |
| 10) Transfer timer to rapid charge                            | :60min               |
| 11) Total rapid charge timer                                  | :1.5h                |
| 12) Total charge timer  | :10 to 20 h          |
| 13) Ambient temperature for rapid charge                      | :0 to 47°C           |